



Rewarding Learning

General Certificate of Secondary Education  
2022

Centre Number

--	--	--	--	--

Candidate Number

--	--	--	--

---

# Physics

Unit 1

Higher Tier

<b>MV18</b>
-------------

[GPY12]

**TUESDAY 7 JUNE, MORNING**

---

## Time

1 hour 30 minutes, plus your additional time allowance.

## Instructions to Candidates

Write your Centre Number and Candidate Number in the spaces provided at the top of this page.

**You must answer the questions in the spaces provided.**

**Do not write on blank pages.**

Complete in black ink only.

Answer **all** questions.

## Information for Candidates

The total mark for this paper is 100.

Figures in brackets printed at the end of each question indicate the marks awarded to each question or part question.

Quality of written communication will be assessed in Question **2(b)**.

- 1 Two friends, A and B, have a race over a distance of 80 metres.  
On the grid below are their distance–time graphs.

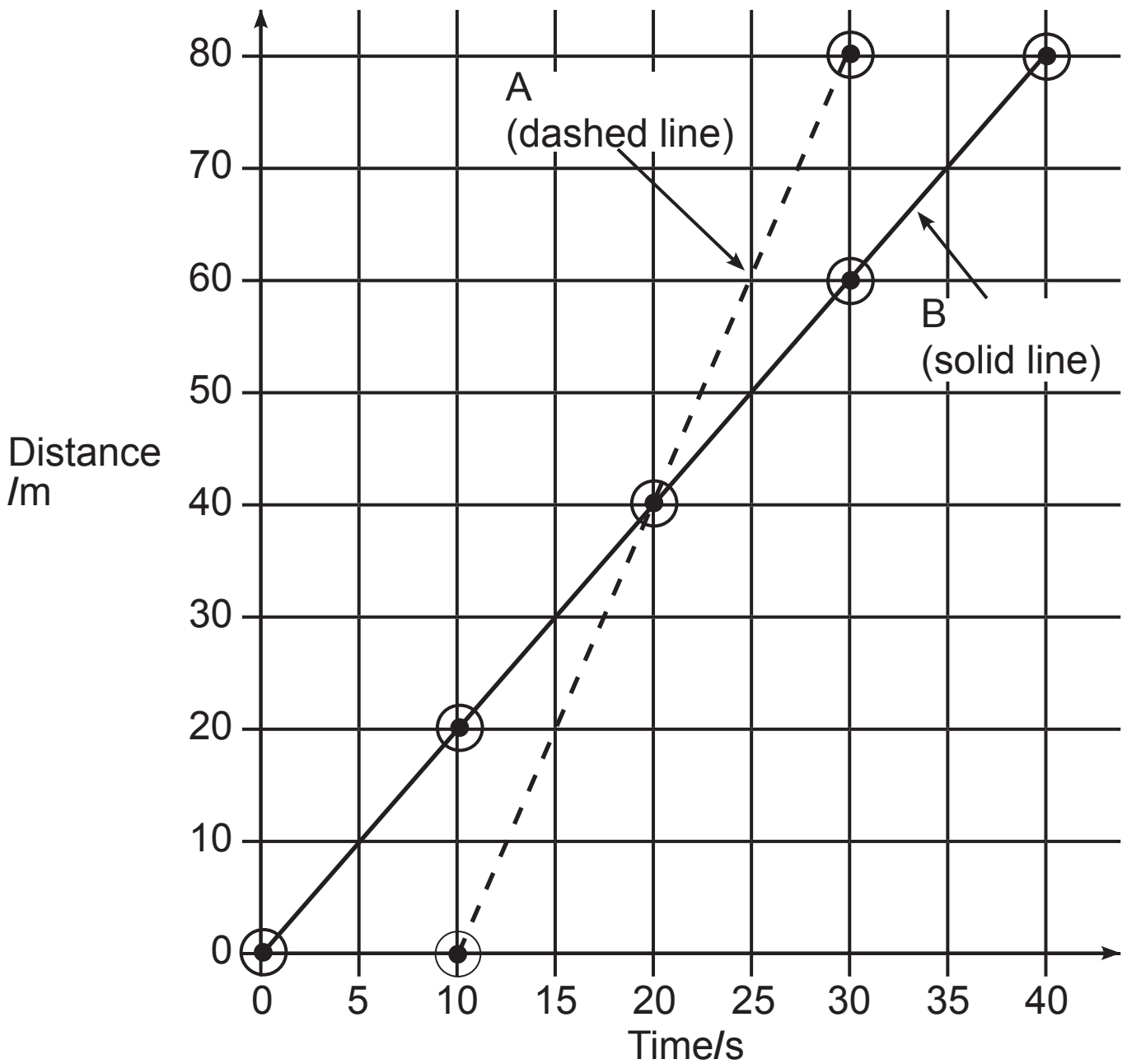

- (a) (i) How far in front is B when A begins to run?  
[1 mark]

\_\_\_\_\_ m

(ii) For how many seconds has B been running when he is overtaken by A? [1 mark]

\_\_\_\_\_ s

(iii) Calculate the speed of A during the race.  
[4 marks]

**Show clearly how you get your answer, starting with the equation you plan to use.**

Speed of A = \_\_\_\_\_ m/s

- (b) As a marble rolls from rest down a slope, it accelerates. The velocity–time graph for the marble is shown below.

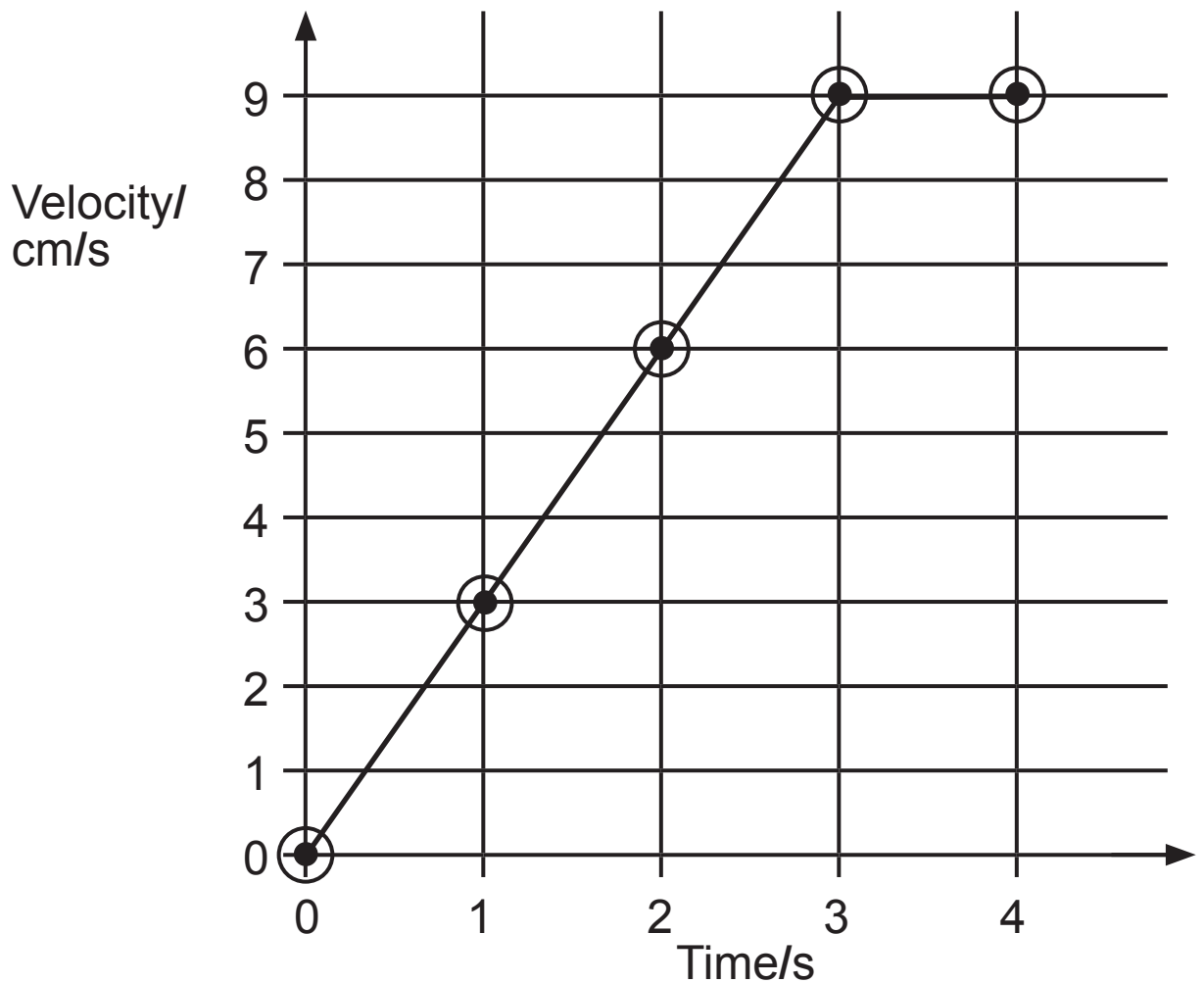

- (i) Calculate the total displacement of the marble in the 4 seconds of its motion. [4 marks]  
**Show clearly how you get your answer.**

Total displacement = \_\_\_\_\_ cm

- (ii) Calculate the acceleration of the marble as it rolls down the slope in the first 3 seconds. [3 marks]  
**Show clearly how you get your answer, starting with the equation you plan to use.**

Acceleration = \_\_\_\_\_ cm/s<sup>2</sup>

- (c) (i) Explain the difference between a vector and a scalar. [3 marks]

---

---

State one example of a vector and one example of a scalar.

Example of a vector: \_\_\_\_\_

Example of a scalar: \_\_\_\_\_

(ii) The world record for a Formula 1 racing car to complete 1 lap of the Silverstone Racing Circuit is 90.6 s.

The distance around the track is 5.89 km.

Explain why the car's average velocity was 0 m/s.

[1 mark]

---

---

(d) A ball bounces and then begins to rise vertically from the ground with a velocity of 6 m/s.

(i) Calculate the time taken for the ball to reach its maximum height. [3 marks]

**Show clearly how you get your answer, starting with the equation you plan to use.**

Time = \_\_\_\_\_ s

- (ii) Using your answer to part (i), or otherwise, calculate the maximum height reached by the ball.  
[4 marks]  
**Show clearly how you get your answer, starting with the equation you plan to use.**

Maximum height = \_\_\_\_\_ m

- 2 (a) During an experiment to investigate the stretching of a spring, values of the force and the extension were recorded and plotted on the grid below.

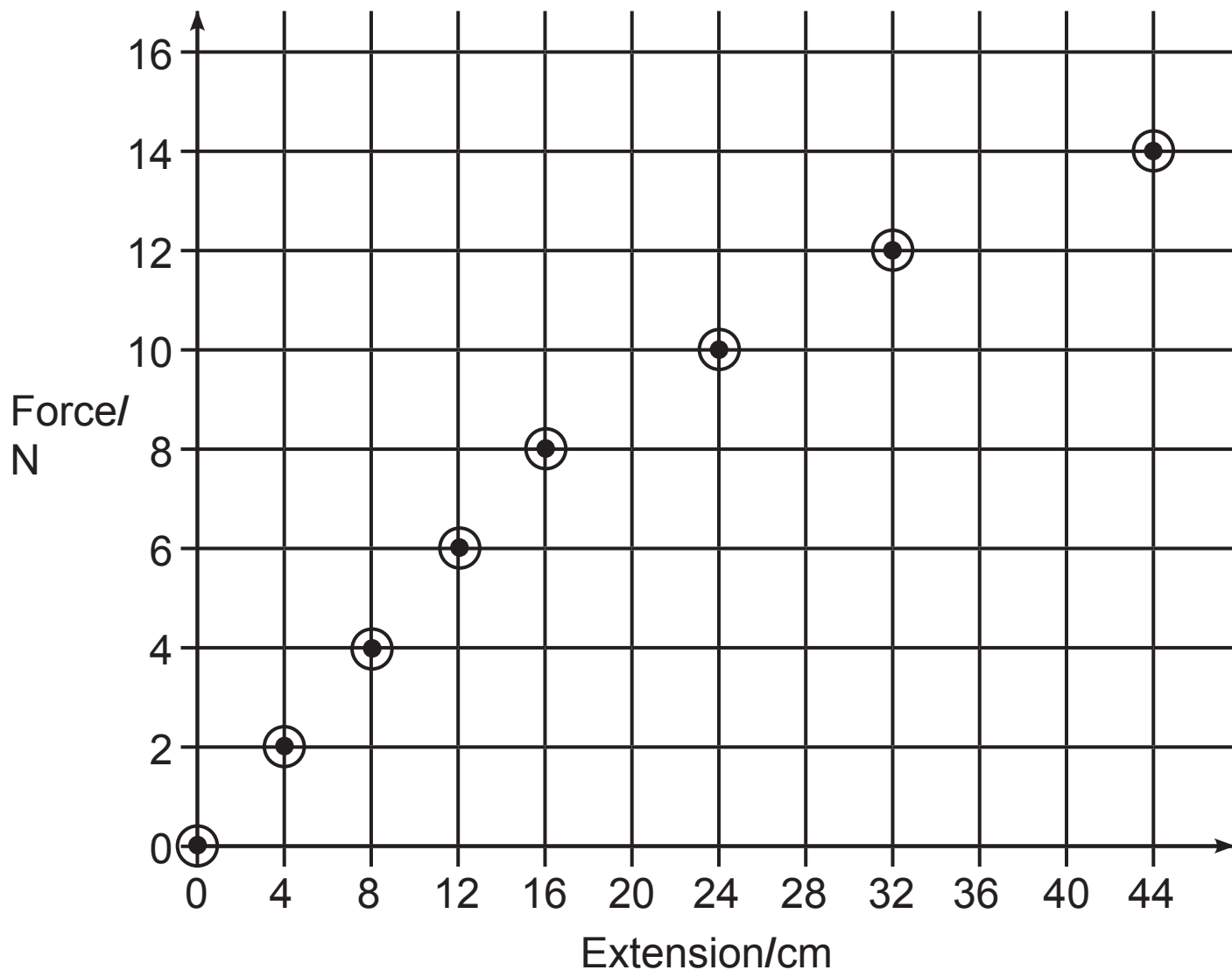

- (i) Draw a line through all the points and use it to estimate the force that corresponds to the limit of proportionality for the spring. [2 marks]

Force = \_\_\_\_\_ [2]

- (ii) Using the data shown in the graph, calculate the spring constant for the spring.  
State the unit of the spring constant with your answer. [4 marks]  
**Show clearly how you get your answer.**

Spring constant = \_\_\_\_\_

Unit = \_\_\_\_\_

- (iii) On the grid opposite draw the graph that would be obtained for a spring with a spring constant half the value of the one shown.  
Stop your graph at 8 N. [2 marks]

(b) The diagram shows a double-decker bus undergoing a tilt test.

The centre of gravity is an important concept when dealing with the stability of an object such as a double-decker bus.

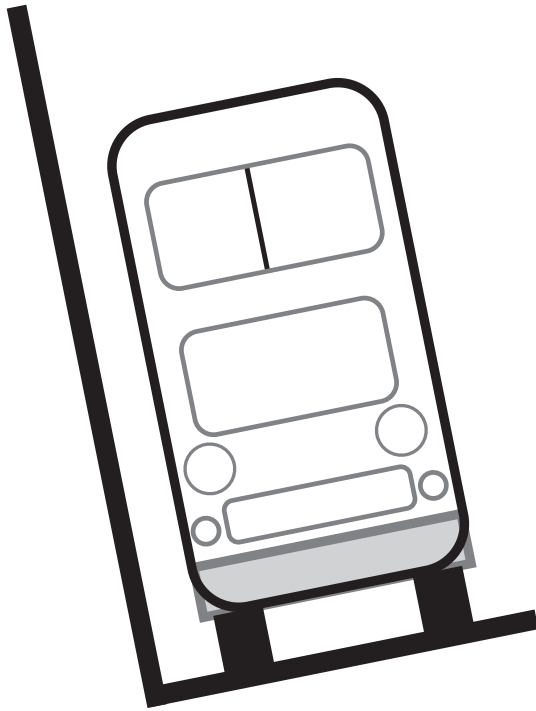

Describe the role the centre of gravity and other factors play in the stability of the double-decker bus. [6 marks]  
In your answer you should state:

- the meaning of centre of gravity;
- how the position of the centre of gravity affects stability;
- another factor affecting stability;
- why standing on the upper deck of such a bus is not allowed;
- what causes the bus to fall over if it is tilted beyond a certain angle.

**In this question you will be assessed on your written communication skills including the use of specialist scientific terms.**

Write your answers below.

Centre of gravity \_\_\_\_\_

---

---

Centre of gravity and stability \_\_\_\_\_

---

---

Other factor affecting stability \_\_\_\_\_

---

---

Standing on the upper deck \_\_\_\_\_

---

---

Cause of bus falling over \_\_\_\_\_

---

---

---

---

(c) The forces acting on a car of mass 2000 kg are shown in the diagram below.



The acceleration of the car is  $0.4 \text{ m/s}^2$ .

Calculate the size of the resistive force. [4 marks]

**Show clearly how you get your answer, starting with the equation you plan to use.**

Resistive force = \_\_\_\_\_ N

(d) A uniform metre rule is pivoted at the 30 cm mark. It is balanced by a 4 N force at the 20 cm mark.

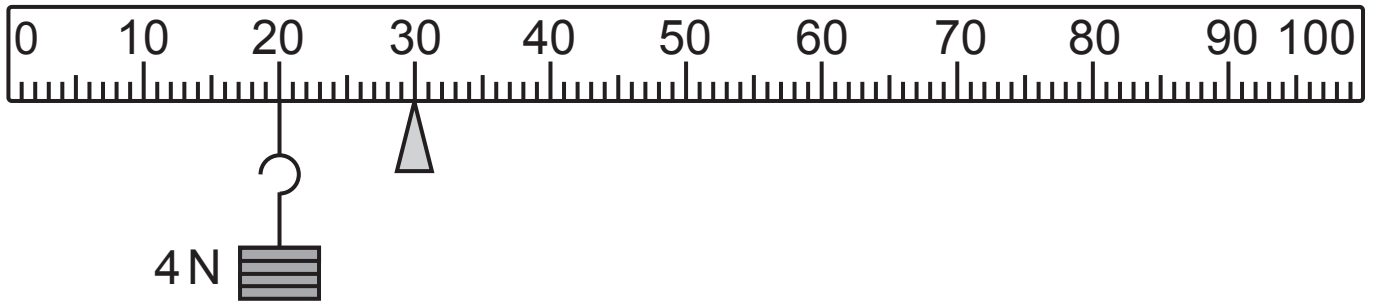

Calculate the weight of the metre rule. [4 marks]  
**Show clearly how you get your answer.**

Weight of the metre rule = \_\_\_\_\_ N

(e) The diagram shows one tyre of a car in contact with the road.

The downward force on the road is 5000 N and the pressure that the tyre exerts on the road is  $2.5 \times 10^5 \text{ Pa}$ .

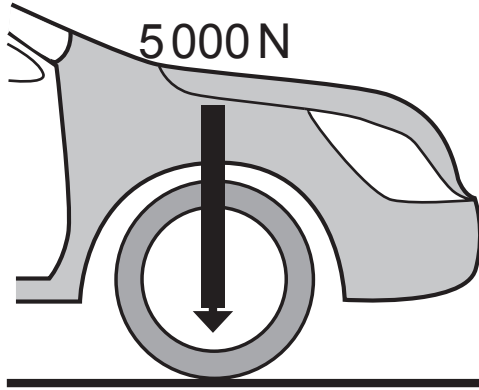

Calculate the area of the tyre in contact with the road.

[3 marks]

**Show clearly how you get your answer, starting with the equation you plan to use.**

Area = \_\_\_\_\_  $\text{m}^2$

- 3 (a) An experiment is carried out by a student to find the density of a metal.  
The metal object to be used has an irregular shape.

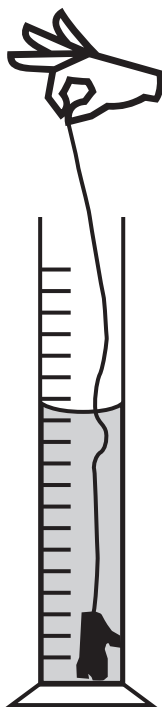

- (i) Briefly describe how the student would accurately measure the volume of water in the measuring cylinder. [1 mark]

---

---

- (ii) The metal object is placed in a measuring cylinder which initially contained  $220\text{ cm}^3$  of water. The metal object has a volume of  $28\text{ cm}^3$ .  
What would the reading on the measuring cylinder be after the metal object is added? [1 mark]

**Show clearly how you get your answer.**

Reading on the measuring cylinder = \_\_\_\_\_  $\text{cm}^3$

- (iii) The density of the metal is found to be  $2.7 \text{ g/cm}^3$ .  
Using the information in part (ii) calculate the mass of the metal object. [3 marks]  
**Show clearly how you get your answer, starting with the equation you plan to use.**

Mass = \_\_\_\_\_ g

(iv) The graph below shows how the volume of a metal of density  $2.7 \text{ g/cm}^3$  varies with mass. Label each axis with the quantity and unit. [2 marks]

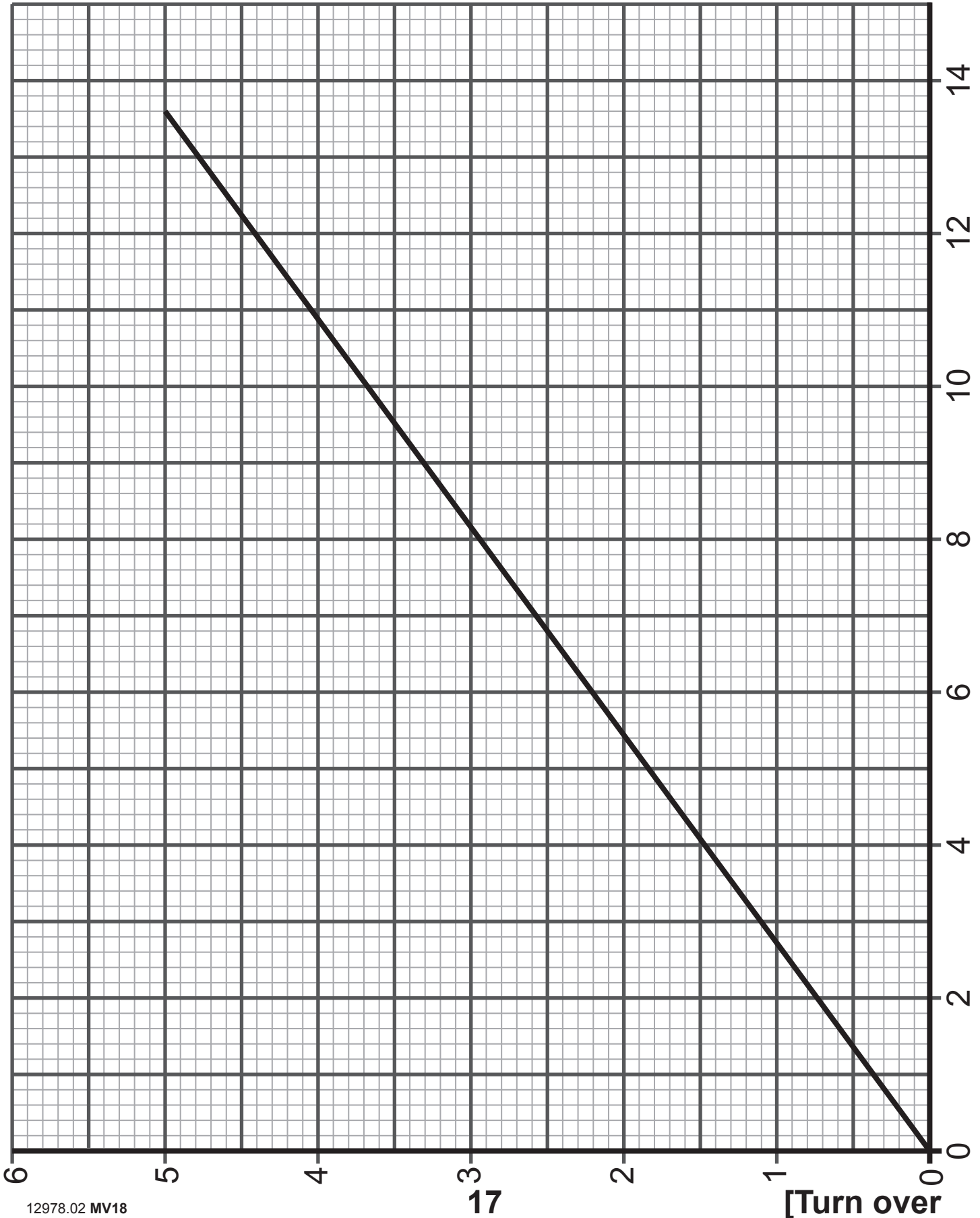

- (b) (i)** The metal has a density of  $2.7 \text{ g/cm}^3$  and water has a density of  $1.0 \text{ g/cm}^3$ .  
Use the kinetic theory of matter to explain why water has a lower density than the metal. [1 mark]
- 
- 

- (ii)** The kinetic theory describes matter as a large number of particles.  
The following statements are about the particles that are found in solids, liquids and gases.

In each box, state whether the statement relates to the particles in a solid, a liquid or a gas. [3 marks]

<b>Statement</b>	<b>Solid, Liquid or Gas</b>
The particles have large gaps between them and are entirely free to move.	
The particles are mainly touching but have small gaps between them.	
The particles have strong forces between them.	

- 4 (a) (i) The table below lists a number of energy resources. Tick (✓) the appropriate box to classify them as renewable or non-renewable. [2 marks]

Energy resource	Renewable	Non-renewable
Coal		
Nuclear Fission		
Sunlight		
Geothermal		

- (ii) In what way does coal pollute the atmosphere?  
Explain your answer. [1 mark]

---

---

(b) The energy flow diagram for a food mixer is shown below.

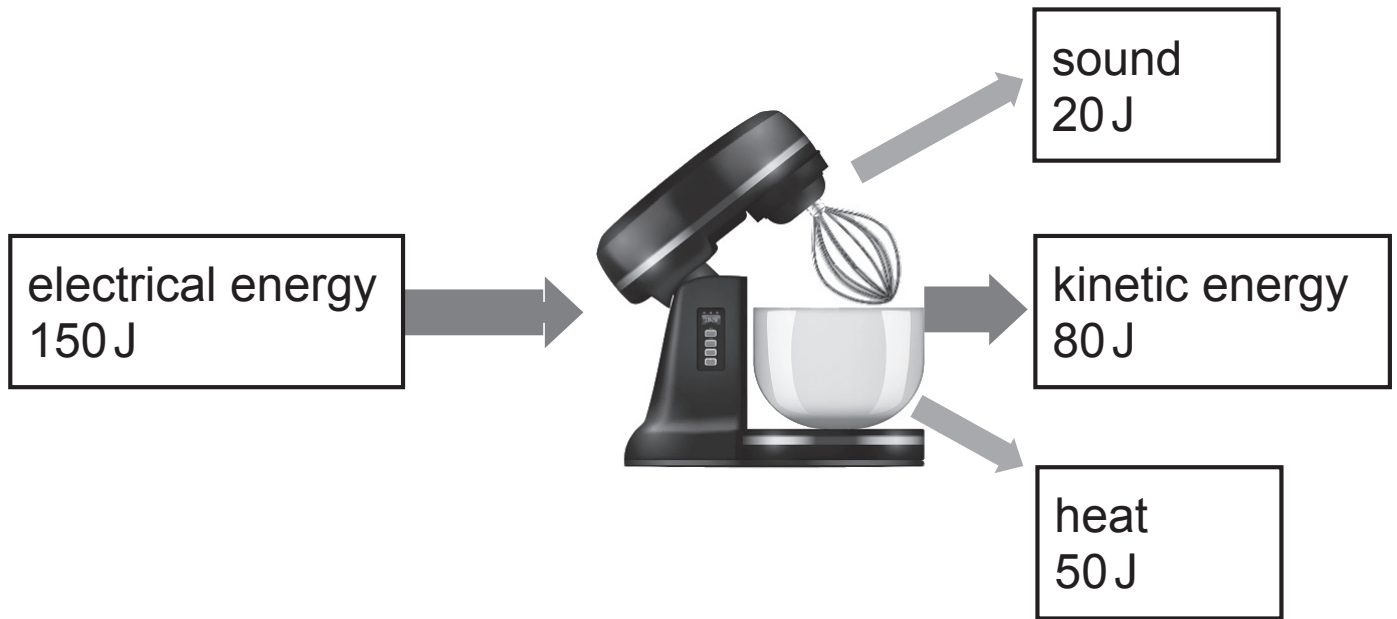

Using the data in the diagram, calculate the efficiency of the food mixer. [4 marks]

**Show clearly how you get your answer, starting with the equation you plan to use.**

Efficiency = \_\_\_\_\_

(c) A car of mass 500 kg is travelling at a velocity of 20 m/s.

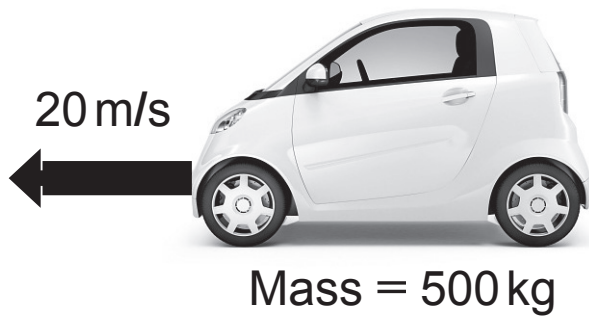

- (i) Calculate the kinetic energy of the car. [3 marks]  
**Show clearly how you get your answer, starting with the equation you plan to use.**

Kinetic energy = \_\_\_\_\_ J

The driver applies the brakes and brings the car to a stop in 50 m.

- (ii) How much work is done by the brakes in stopping the car? [1 mark]

Work done = \_\_\_\_\_ J

- (iii)** The car has a brake on each of its four wheels.  
Calculate the average force provided by **each** brake  
in stopping the car. [4 marks]  
**Show clearly how you get your answer, starting  
with the equation you plan to use.**

Average force = \_\_\_\_\_ N

- (iv)** What two forms of energy is the kinetic energy of the  
car changed into while braking? [1 mark]  
\_\_\_\_\_ and \_\_\_\_\_

- (d) The International Space Station orbits the Earth at a distance of 400 km.

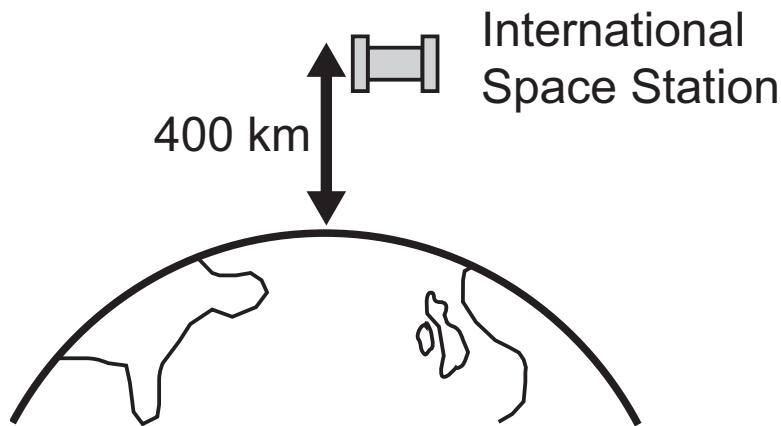

- (i) The International Space Station has a mass of  $4.2 \times 10^5 \text{ kg}$ .  
Show that the gravitational potential energy of the International Space Station is  $1.68 \times 10^{12} \text{ J}$ .  
Assume the acceleration of free fall is the same at a height of 400 km as it is on the surface of the Earth.  
[3 marks]  
**Show clearly how you get your answer, starting with the equation you plan to use.**

(ii) The International Space Station is regularly supplied by rockets.

When a supply rocket reaches the Space Station it has a potential energy of  $0.3 \times 10^{11}$  J and a kinetic energy of  $2.0 \times 10^{11}$  J.

The rocket takes 600 s to reach the Space Station. Calculate the average power developed by the engines of the supply rocket. [3 marks]

**Show clearly how you get your answer, starting with the equation you plan to use.**

Average power = \_\_\_\_\_ W

**Blank Page**

**(Questions continue overleaf)**

(e) To investigate how quickly hot water cools, the apparatus shown below was used. Each identical beaker contains the same volume of water. The initial temperature of the water in one beaker was  $100^{\circ}\text{C}$  and in the other beaker the initial temperature was  $50^{\circ}\text{C}$ . The temperature of the water in each beaker was recorded at one-minute intervals for five minutes. The graphs below show the results of the investigation.

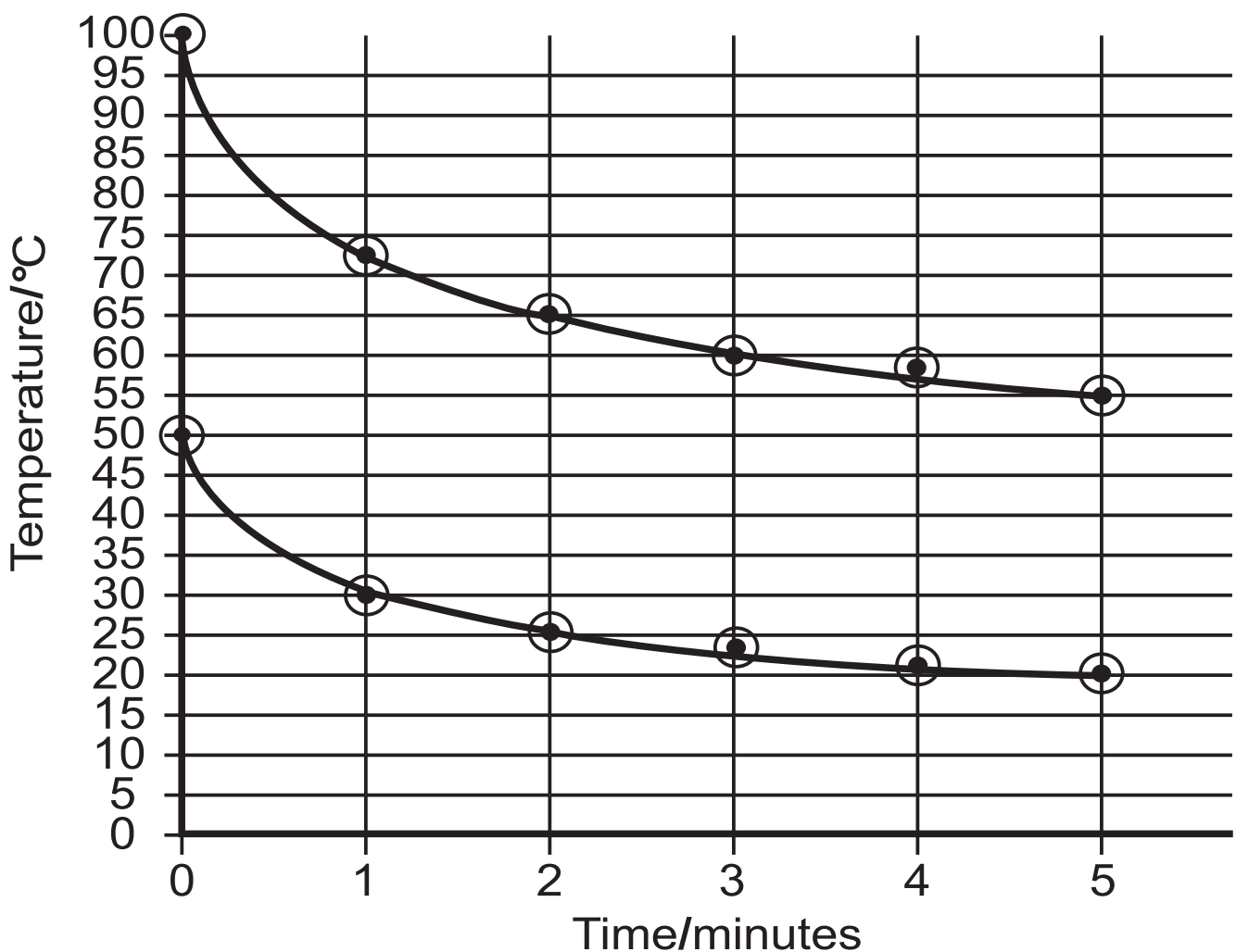
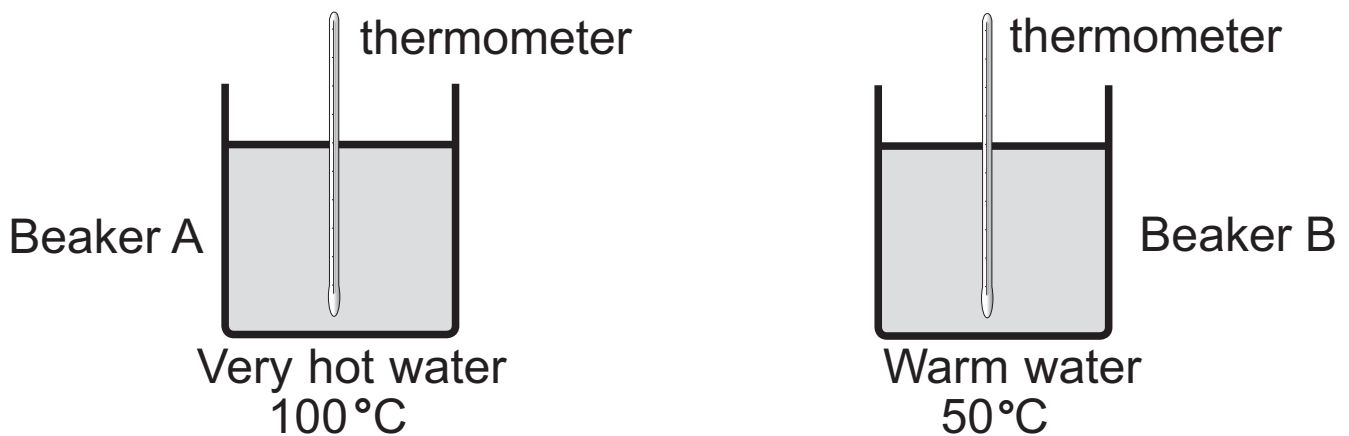

Which beaker has cooled more quickly in the 5 minutes?  
Support your answer with two appropriate calculations.  
[2 marks]

Beaker \_\_\_\_\_

Calculation 1. \_\_\_\_\_

Calculation 2. \_\_\_\_\_

5 (a) Radiocarbon dating is a method for determining the age of a wooden object.

All wood contains an isotope of carbon which is radioactive.

(i) Complete the decay equation for this isotope of carbon. Write the appropriate numbers and symbol in the boxes provided. [3 marks]



(ii) A piece of wood from an ancient spear has an activity of 4 disintegrations per minute recorded due to the decay of this isotope of carbon.

A fresh piece of wood of the same mass has an activity of 32 disintegrations per minute. This is also due to the decay of this isotope of carbon.

The half-life of this isotope of carbon is 5730 years.

Calculate the age of the wood from the ancient spear. [3 marks]

**Show clearly how you get your answer.**

Age of the wood from ancient spear = \_\_\_\_\_ years

**Blank Page**

**(Questions continue overleaf)**

(b) The range of alpha ( $\alpha$ ) particles in air may be investigated using the equipment shown below.

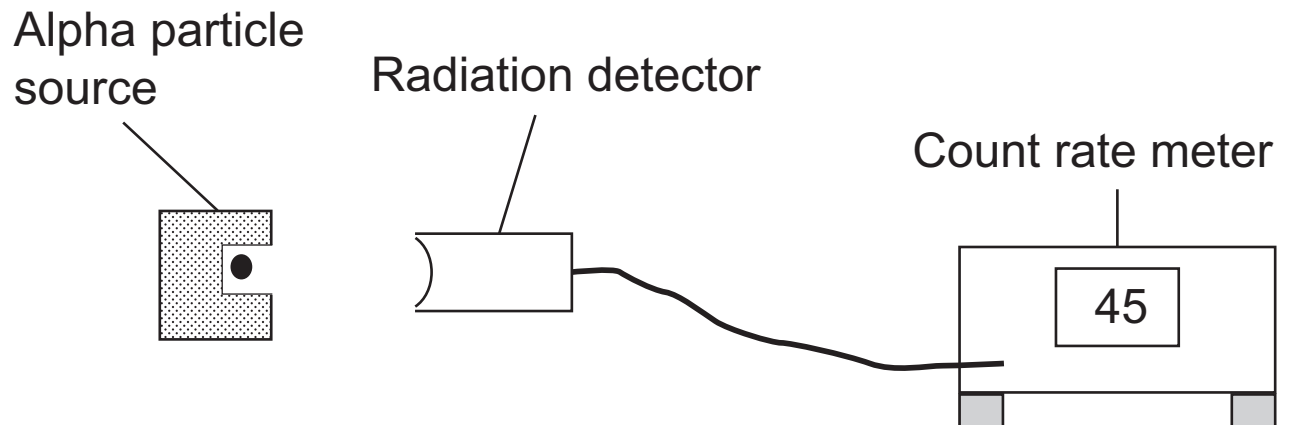

The distance between the alpha source and the radiation detector is changed. The reading on the count rate meter is noted in counts per second (cps) for each distance.

A graph of the count rate against the distance was plotted as shown opposite.

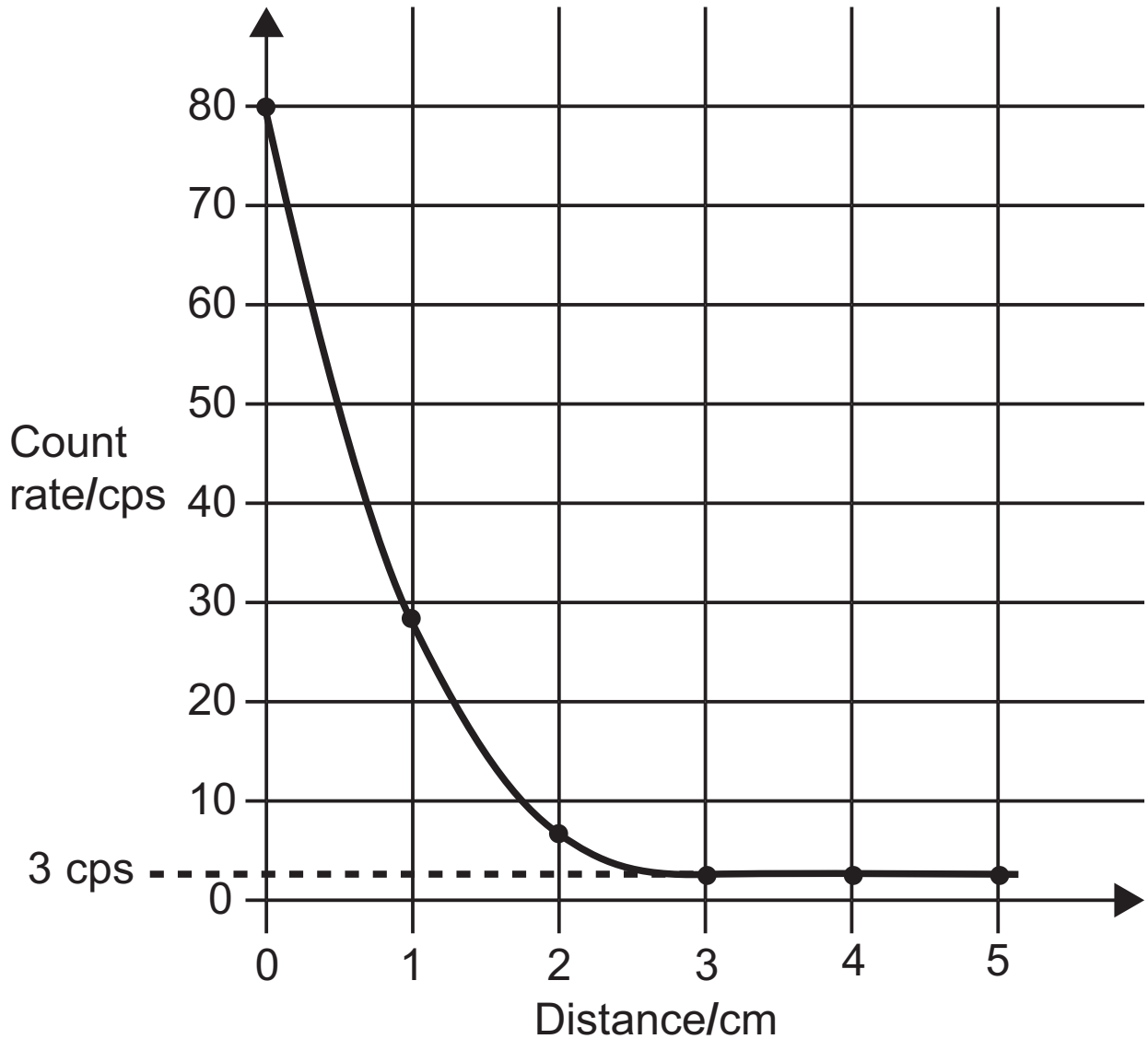

You will notice that the graph never shows a reading of less than 3 cps.

(i) What name is given to this constant reading?  
[1 mark]

---

(ii) What is the source of this constant reading?  
[1 mark]

---



---

(iii) Using the graph, estimate the range of the alpha particles in air. [1 mark]

Range = 0 cm to \_\_\_\_ cm

(c) Nuclear radiation can present danger to living organisms.

Explain why nuclear radiation is dangerous to living cells and state what damage it can cause. [2 marks]

---

---

---

---

(d) Nuclear fusion is a possible source of energy for the future.

(i) The nuclei of which three isotopes could be used as fuel in a fusion reactor? [3 marks]

---

---

---

(ii) We have an almost limitless supply of fusion fuel here on earth.

Where can it be found? [1 mark]

---

(iii) Name the element that is the major by-product of nuclear fusion. [1 mark]

---

---

**This is the end of the question paper**

---





## SOURCES

- Q1 . . . . Source: *Chief Examiner*
- Q1(b) . . . Source: *Chief Examiner*
- Q2(a) . . . Source: *Chief Examiner*
- Q2(b) . . . Source: *Chief Examiner*
- Q2(c) . . . Source: © *Getty Images*
- Q2(d) . . . Source: *Chief Examiner*
- Q2(e) . . . Source: *Chief Examiner*
- Q3(a) . . . Source: *Chief Examiner*
- Q4(b) . . . Source: © *Getty Images*
- Q4(c) . . . Source: © *Getty Images*
- Q4(d) . . . Source: *Chief Examiner*
- Q4(e) . . . Source: *Chief Examiner*
- Q5(b) . . . Source: *Chief Examiner*

For Examiner's use only	
Question Number	Marks
1	
2	
3	
4	
5	

<b>Total Marks</b>	
--------------------	--

Examiner Number

Permission to reproduce all copyright material has been applied for.  
In some cases, efforts to contact copyright holders may have been unsuccessful and CCEA will be happy to rectify any omissions of acknowledgement in future if notified.